

## Container 900 Liter, Typ TCO 9/L

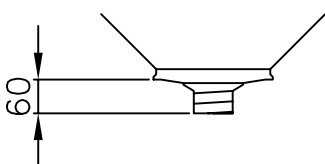
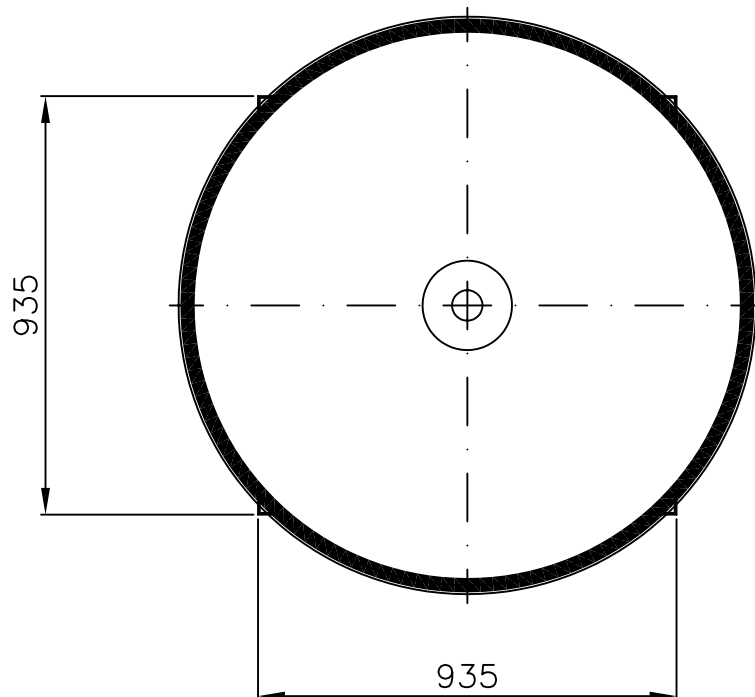
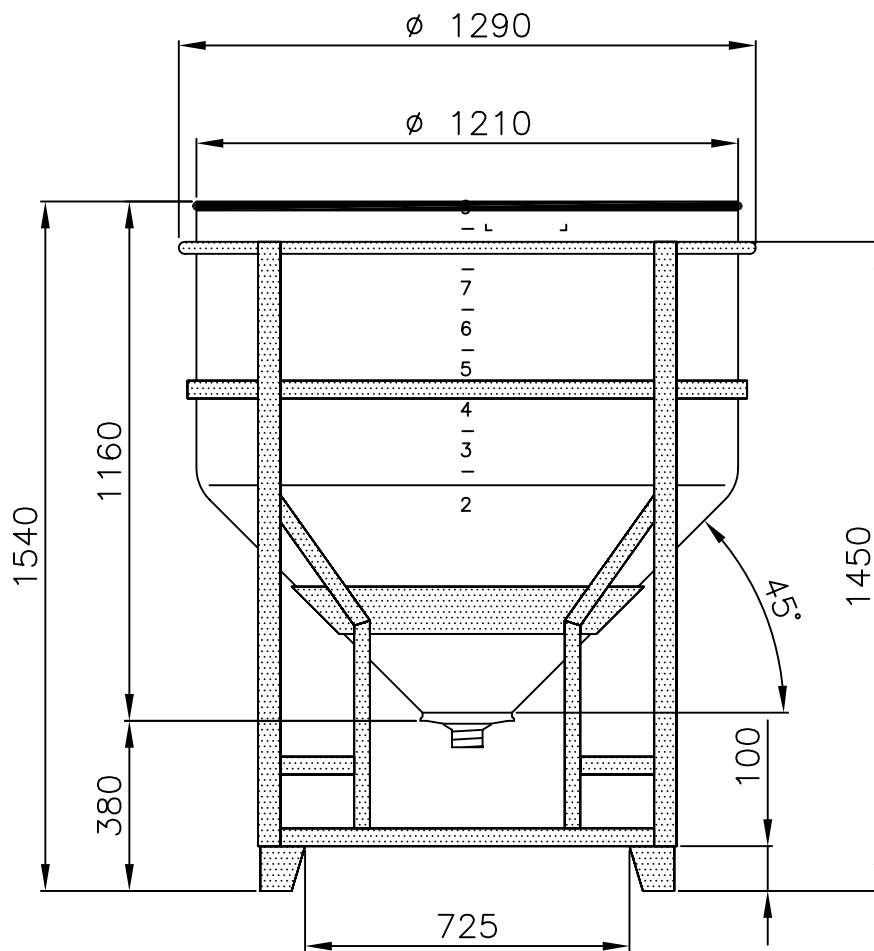

Entleerung :  $\varnothing 1'' - 1\frac{1}{4}'' - 1\frac{1}{2}'' - 2''$  Containerhöhe = 1540 mm  
 Entleerung  $\varnothing 2\frac{1}{2}'' - 3'' - 4''$  Containerhöhe = 1660 mm